

CARE AND USE OF THE VP 179A JIG WITH ASPIRATION MANIFOLD

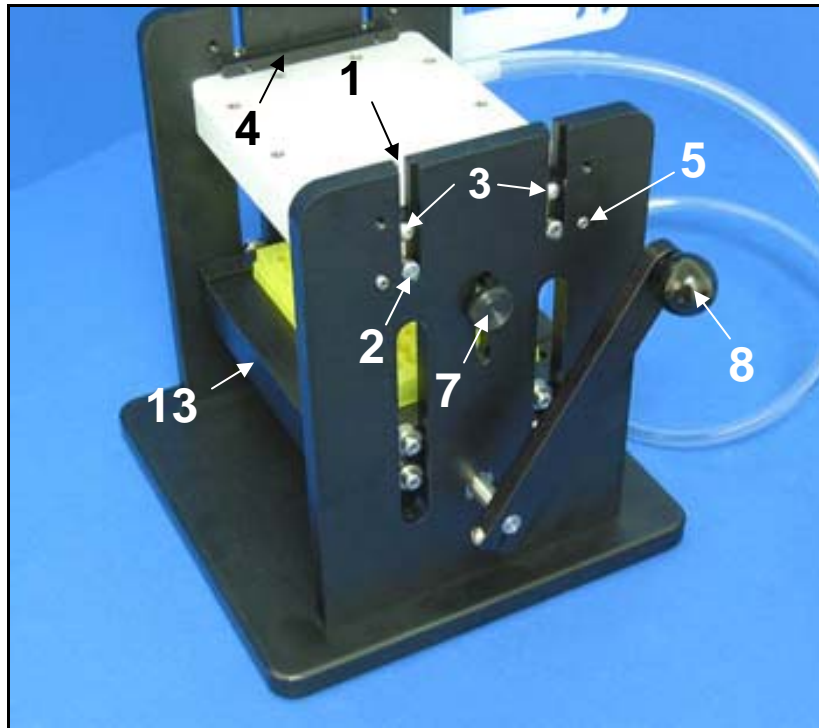

Figure 1: VP 179A Jig with Aspiration Manifold

PARTS GUIDE FOR VP 179A MANIFOLD JIG

1 – Jig Slot for Shoulder Bolt	6 – Y Position Screw	11 – Vacuum Tube Support Arm
2 – Shoulder Bolt Head	7 – Z Bar Stop Thumb Screw	12 – Vacuum Tubing
3 – Manifold Hold-Down Screw	8 – Z Arm Lever	13 – Microplate Platform
4 – Manifold Hold-Down Bar	9 – Z Arm Nylon Pressure Screw	14 – Spacer
5 – X Positioning Screw	10 – Vacuum Outlet Fitting	15 – “Rapier” (not shown)

SETUP FOR ASPIRATION MANIFOLD ON JIG

Attaching the Manifold

1. Loosen Manifold Hold-Down Screws (3) using the 1/16 Allen wrench and remove the Manifold Hold Down Bars (4) (Figure 1).
2. Place the shoulder bolt heads (2) of the Manifold into the Jig slot (1) and slide down into the slots until shoulder bolts hit the bottom of the slots.
3. Place the Manifold Hold-Down Bars (4) on top of the Manifold and tighten the Manifold Hold-Down Screws (3) to secure the Manifold in the Jig (Figure 2a).

Setting the X and Y Positions

1. Slide a microplate into the Microplate Platform (13). Use the Allen wrench provided to adjust the X and Y Manifold position so it is in the center of the wells of the microplate (Figure 2a and b).
2. When adjusting the X Position always loosen the X Positioning Screws first in the direction the manifold is to be moved before tightening the opposing X Positioning Screws. Failure to do this can pull the Shoulder Bolt (2) out of the Manifold and strip the threads.

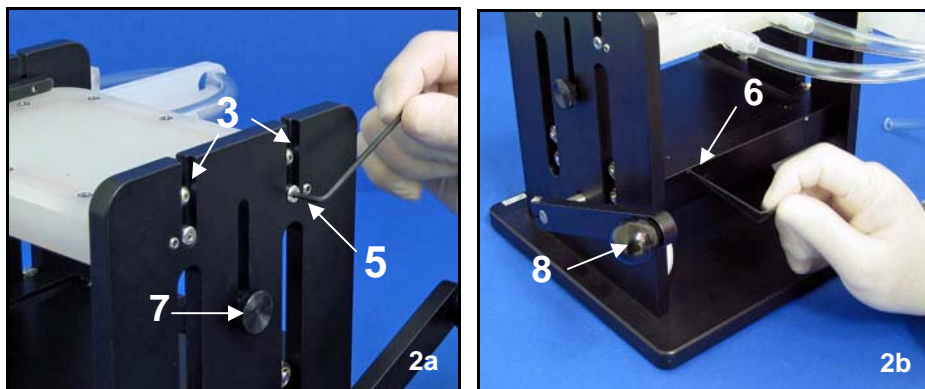

Figure 2: Securing Manifold in Jig (a). Adjusting X (a) and Y (b) Positions.

3. For more precise positioning use one of the Registration Plates VP 903R-96, VP 903R-384 or VP 903R-1536 (Figure 3). Place the Registration Plate into the Microplate Platform (13) where the microplate would go and push against the back wall. Pull the Z Arm Lever (8) down until the Manifold tubes are just over the Registration Plate. Tighten the Z Arm Nylon Press Screw (9) to hold the Microplate Platform (13) in position (Figure 4). Line up the white 1mm corner spots of the Registration Plate with the corner tubes on the Manifold. This is done by using the provided 0.5 Allen wrench to adjust the X and Y Position Screws (5 and 6) as shown in Figure 2.

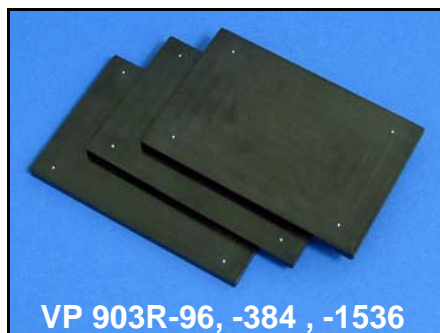

Figure 3: Registration Plates

Setting the Z Height

1. Use the thumbscrew to loosen the Z Bar Stop (7) (Figure 4a).

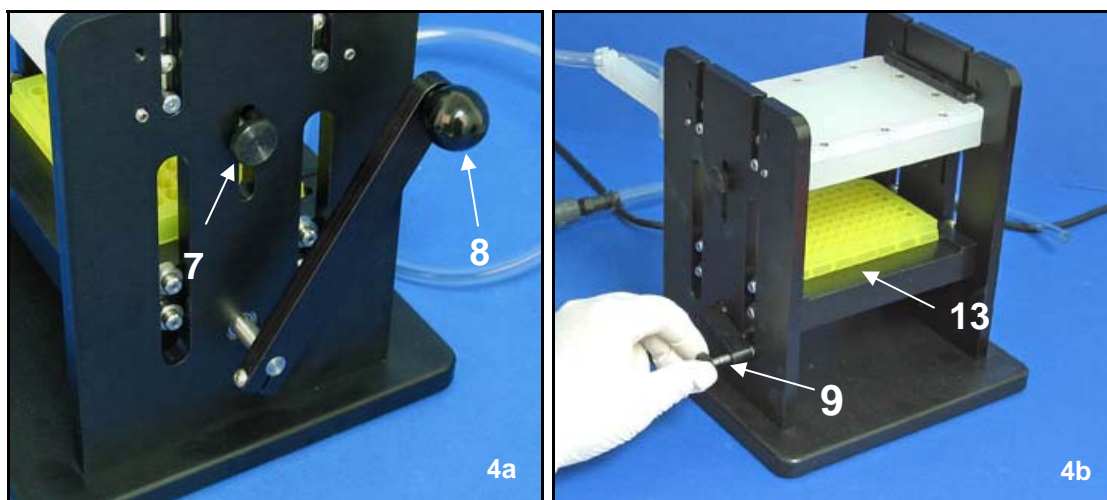

Figure 4: (A) Adjusting Z Bar Stops. (B) Adjusting Nylon Pressure Screw for Z Arm control.

2. Slide an empty microplate into the Microplate Platform (13). To set the plate height where the pins stop ~1mm from the bottom of the wells, place a 1mm thick piece of paper, or “Spacer” (14) under the microplate. Raise the Z Arm Lever (8) until the metal tubes just touch the bottom of the wells.

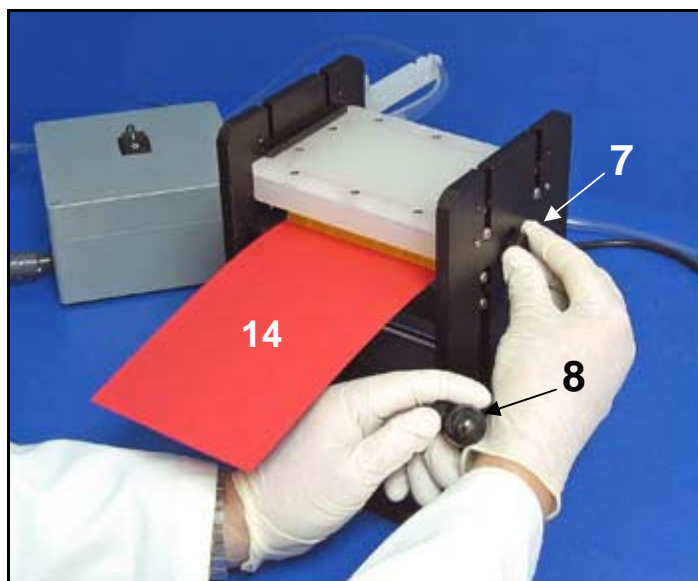

Figure 5: (A) Adjusting Z height using a Spacer

3. To hold Microplate Platform (13) in this “up” position, tighten Z Arm Nylon Pressure Screw (9).
4. Tighten the Z Bar Stop Thumb Screws (7) to lock the maximum microplate position in place.
5. Loosen the Nylon Pressure Screw (9), lower the Microplate Platform and remove the microplate.
6. Remove the paper spacer from the Microplate Platform and a 1mm space will be set in the system.

Connecting the Manifold to Vacuum System

1. Connect the vacuum source to a vacuum trap (Figure 5).

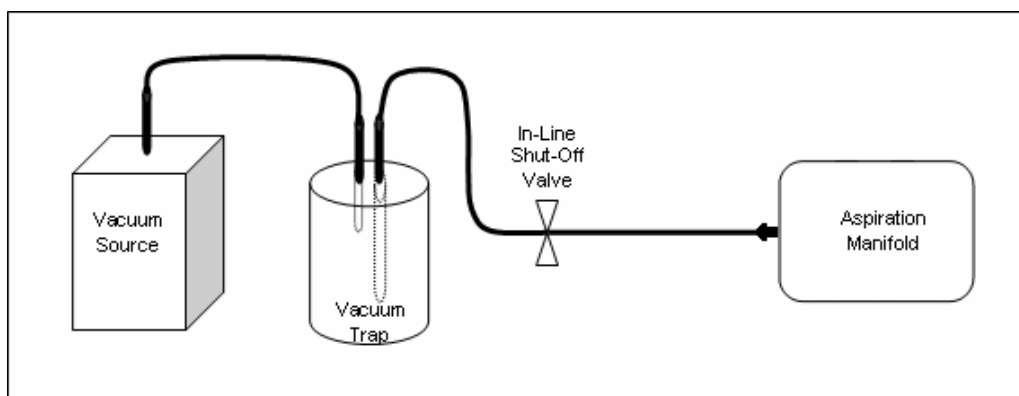

Figure 5: Vacuum System Connection

2. Connect the vacuum trap to an in-line shut-off valve such as stop cock valve or a VP 600 Push Button (both are shown in Figure 6). The V&P 600 provides the ease of turning off and on with the push of a button or by computer/robot. The stopcock valve requires two hands to operate.

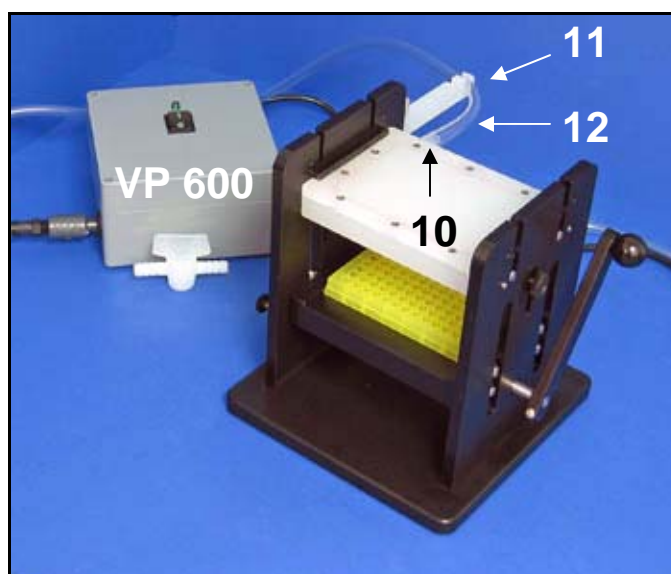

Figure 6: VP 600 Push Button In-Line Shut-Off Valve.

4. Connect the in-line shut-off valve to the Vacuum Outlet Fitting (10) with Vacuum Tubing (12).
5. Place the Vacuum Tubing (12) in the Support Arm (11) secure to the Jig.

IMPORTANT NOTE:

The Aspiration/Dispense Manifolds are chemically resistant to some common laboratory solvents (such as ethyl alcohol, methyl alcohol, isopropanol, DMSO) but not all (acetone or chloroform, for example). Please contact V&P Scientific for more information if there is any question regarding the chemical resistance of the Manifold to the solution to be aspirated or dispensed.

USING ASPIRATION MANIFOLDS

1. Close in-line shut-off valve. Turn on vacuum pump
2. Place the microplate to be aspirated into the Microplate Platform (13) under the Manifold.
3. Raise the Z Arm Lever (8) to the pre-set Z Height Stop Bar (see Setting Z Height section).
4. Open the shut-off valve to aspirate samples from wells.
5. Lower Z Arm Lever (8) and remove the microplate from the Microplate Platform (13).
6. Close in-line valve to allow pressure to build up in the vacuum trap before aspirating from the next plate.
7. Blot tubes with VP 540DB lint free pads or rinse pins with appropriate fluid in a tray or tip lid box before aspirating from next plate.

TROUBLESHOOTING ASPIRATION MANIFOLDS

1. If you notice a single well not emptying properly, locate the clogged tube corresponding to the well. Insert the “rapier” (metal wire included with the Manifold) into the clogged tube. This should remove the obstruction. Wash the system well after performing this step.
2. Alternatively, the top portion of both the aspiration and dispense Manifolds can be removed; the Manifold examined for clogged tubes and cleaned. Use care not to damage the gasket when removing and replacing the top Manifold section.

STORAGE

1. For short-term storage, keep the tips of the metal aspirate tubes in the liquid you are using or distilled water. This will prevent the liquid from drying and clogging the tubes.
2. For long-term storage, drain the Manifold and aspirate three separate 100 ml distilled water aliquots through the system. **DO NOT USE DE-IONIZED WATER**, as de-ionized water will corrode the stainless steel tubes.
3. Tip the system back and forth after each aliquot to ensure all water is aspirated from the Manifold on each rinse.
4. Aspirate two separate 50-100 ml aliquots of 100% alcohol (methanol, ethanol or isopropyl alcohol) through the Manifold. Tip the system back and forth to ensure all the alcohol is removed.
5. Pull air through the Manifold for 1- 2 minutes by leaving the vacuum on and shut-off valve open.
6. Store in a clean dry area.
7. To autoclave, simply place the entire system into the autoclave. It is not necessary to remove any parts.